

Warning:
Use caution during assembly. Inspect materials for any sharp edges. Adult supervision is required for assembly by individual under the age of 18.

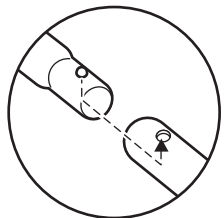

Be sure locking buttons engage when fitting tubes together.

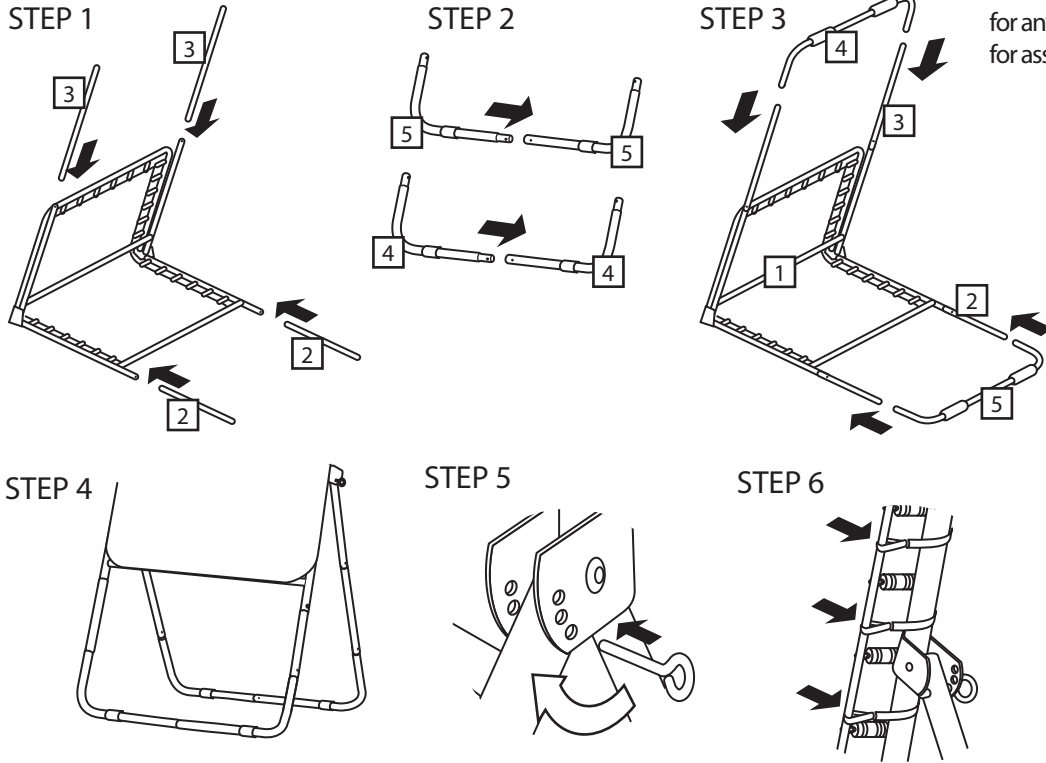
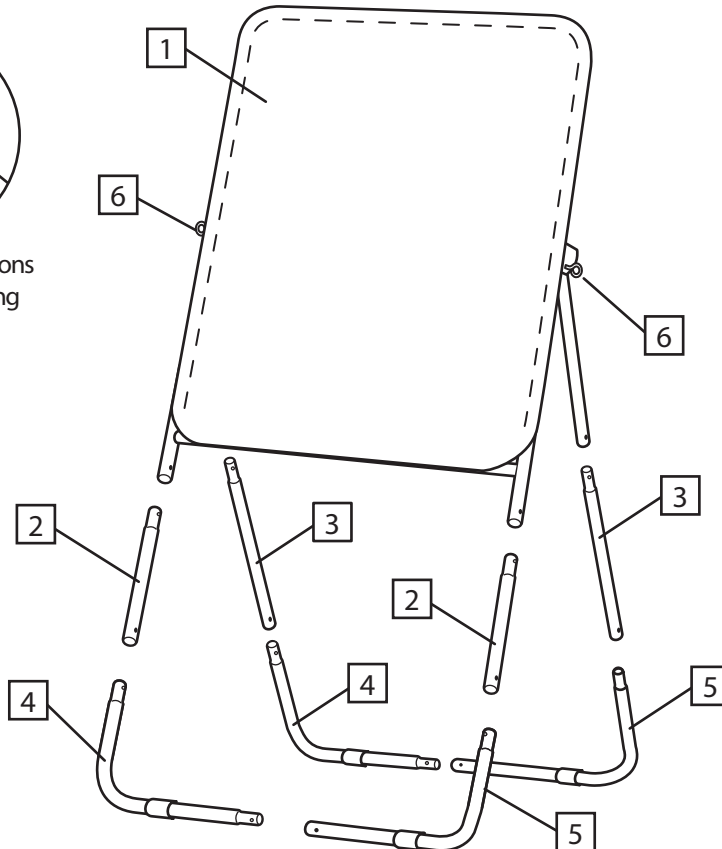

Parts Included:

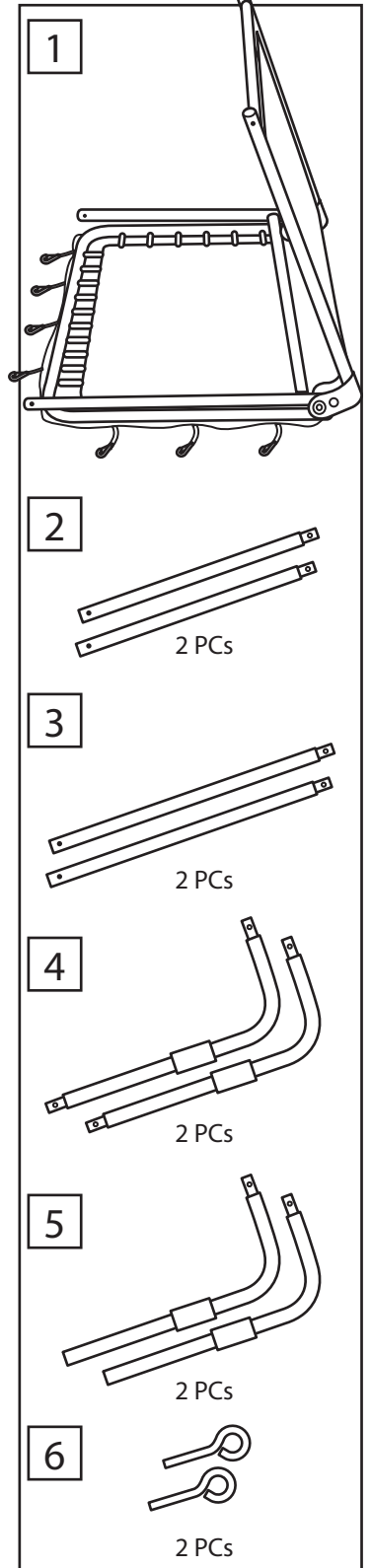



Gladiator Lacrosse stands behind all of its products when used under normal conditions. For help with any issues please visit www.gladiatorlacrosse.com and click the Support link or contact customer service at support@gladiatorlacrosse.com. For a detailed visual assembly please visit our YouTube page at <https://www.youtube.com/watch?v=1TaY7jVYr1s> or use the search phrase, "Gladiator Lacrosse Rebounder Wall Assembly Video."

Gladiator Lacrosse Rebounder Wall Assembly

1. Unpack all parts and check for damage that may have occurred during shipping. If damage has occurred, notify Gladiator Lacrosse. Lay out all parts and check for any missing pieces. Read through entire instruction sheet before assembly.
2. First, unfold the canvas surface. This may take more than one person and is best done on the floor or flat surface. Do not be afraid to use a good amount of force as this is a sturdy piece.
3. Start by attaching the #3 tubes and #2 tubes into the movable steel tubes that are already attached to the back of rebounder canvas surface (See Step 1). *Be sure all locking buttons engage when fitting all tubes together.*
4. Insert the #5 tubes and the #4 tubes to each other, making sure the locking buttons engage (Step 2).
5. Attach the #4 tubes to the #3 tubes and the #5 tube assembly to the #2 tubes already in place (Step 3). This finishes the legs of the rebounder. Stand the rebounder right side up (Step 4).
6. To lock the Rebounder into position, use the pins (pieces #6) and insert them in at the desired angle (Step 5). Make sure they are inserted fully for safety. Take these pins out when you want to fold the Rebounder Wall flat for storage.
7. Lastly, use the black hooks provided for additional support, and, making sure they are attached to the elastic loops (if not already attached), pull and attach to the hooks where metal springs are attached at the back of the canvas surface (Note that there are 4-8 hooks per rebounder).

Gladiator Lacrosse
1081 Holland Drive
Boca Raton, FL 33487
(561) 285-8508
support@gladiatorlacrosse.com